

DM 雙層式手動千斤頂

- 碳鋼底座，自動焊接，品質穩定。
- 主軸採用合金鋼硬鉻處理，耐久不生銹。
- 使用簡便，易攜帶，用途廣泛。
- 本體低、揚程高。

DM Two-stage-Telescopic Jack

- ※ Carbon steel base with automatic welding makes stable quality.
- ※ Alloy steel plunger with chrome plated.
- ※ Easy to use, carry & extensive applications.
- ※ With long travel from low position.

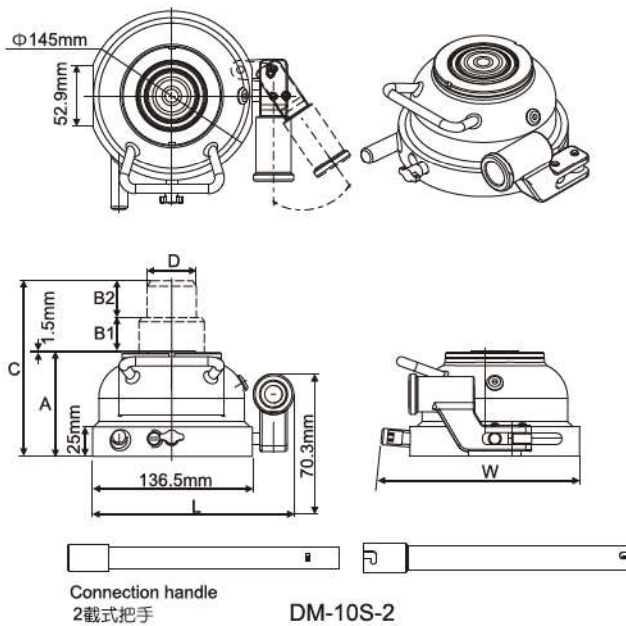

DM-10S-2

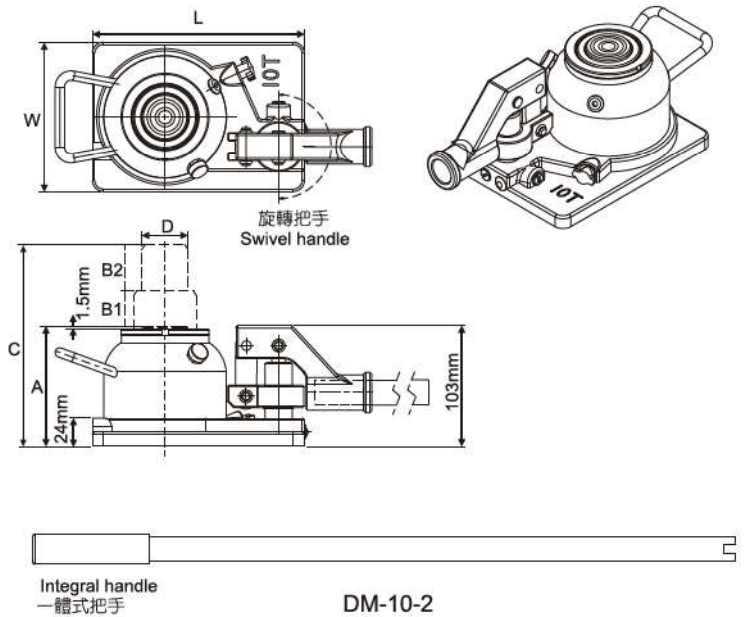

DM-10-2

型號 Model Number	能力 Capacity (ton)	揚程 Stroke (mm)	本身高 Min. Ht. A (mm)	階段高度 Stage Ht. (mm)		伸長總高 Ext. Height C (mm)	最高主軸直徑 Top plunger Diam. D (mm)	底座尺寸 Base Dimensions L x W (mm)	柄管尺寸/樣式 Handle tube (mm)	總重 Weight (kg)
				B1	B2					
DM-10S-2	10	60	90	28.5	30	150	42	171.81 X 170	Φ21.7*425/ 2載式 Connection handle	6.8
DM-10-2	10	70	102	31.5	40	172	39	181 X 128	Φ21.7*600/一體式 Integral handle	7.0